

5. PARTS LIST

5.1 机壳部分

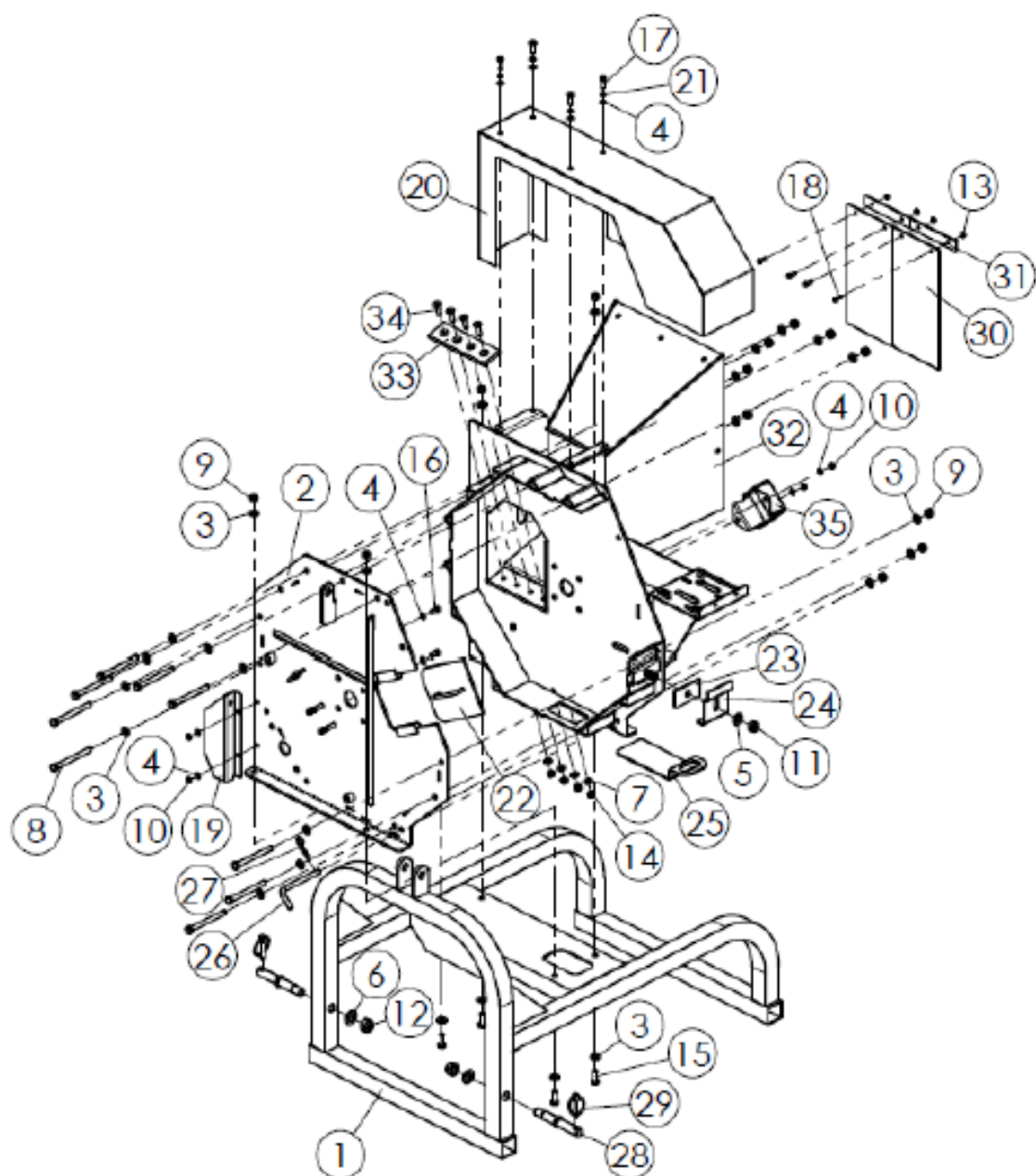

Ser No.	Part No.	Name & Specifications	Quantity
1	WCM8-00011	机架 CHIPPER BASE WELDMENT	1
2	WCM8-00017	后盖 BACK COVER	1
3	GB97.1-85	平垫 12 PLAIN WASHER 12	26
4	GB97.1-85	平垫 8 PLAIN WASHER8	10
5	GB97.1-85	平垫 16 PLAIN WASHER16	1
6	GB97.1-85	平垫 20 PLAIN WASHER20	2
7	GB97.1-85	平垫 10 PLAIN WASHER10	4
8	GB5782-86	螺栓 M12×130BOLTS M12*130	9
9	DIN985-87	螺母 M12 NUTS	13
10	DIN985-87	螺母 M 8 NUTS	4
11	DIN985-87	螺母 M16 NUTS	1
12	DIN985-87	螺母 M20 NUTS	2
13	DIN985-87	螺母 M 6 NUTS	4
14	DIN985-87	螺母 M10 NUTS	4
15	GB5783-86	螺栓 M12×30 BOLTS	4
16	GB5783-86	螺栓 M 8×20 BOLTS	2
17	GB5783-86	螺栓 M 8×25 BOLTS	4
18	GB5783-86	螺栓 M 6×20 BOLTS	4
19	WCM8-00163	挡板 BAFFLE BOARD	1
20	WCM8-00013	减速器罩焊合件 REDUCER COVER	1
21	GB93-87	弹垫 8 SPAING WASHER	4
22	WCM8-00033	窗口封板焊合件 WINDOW COVER	1
23	WCL5-00105	橡胶垫 RUUBER WASHER	1
24	WCM8-00104	压紧板 COMPACT BOARD	1
25	WCM8-00188	抽板 TAKE OUT PLATE	1
26	WCL5-00133	锁销 LOCKING PIN	1
27	.	中 R 销 SMALL R PIN	1
28	WCL5-00101Ke	下悬挂销 DOWN LINK PIN	2
29	200.56.011	锁销组件 combination PIN	2
30	WCL8-00110	塑料挡板 PLASTIC COVER	2
31	WCL8-00111	夹板 COMPACT BOARD	2
32	WCM8-02011	机壳 CHIIPER BODY WELDMENT	1
33	WCL8-02101	定刀 BED BLADE	1
34	GB70.3-2000	螺钉 M10×35 BOLT	4
35	WCM8-00166	下轴端罩 DOWN COVER BOARD	1

5.2 出料部分

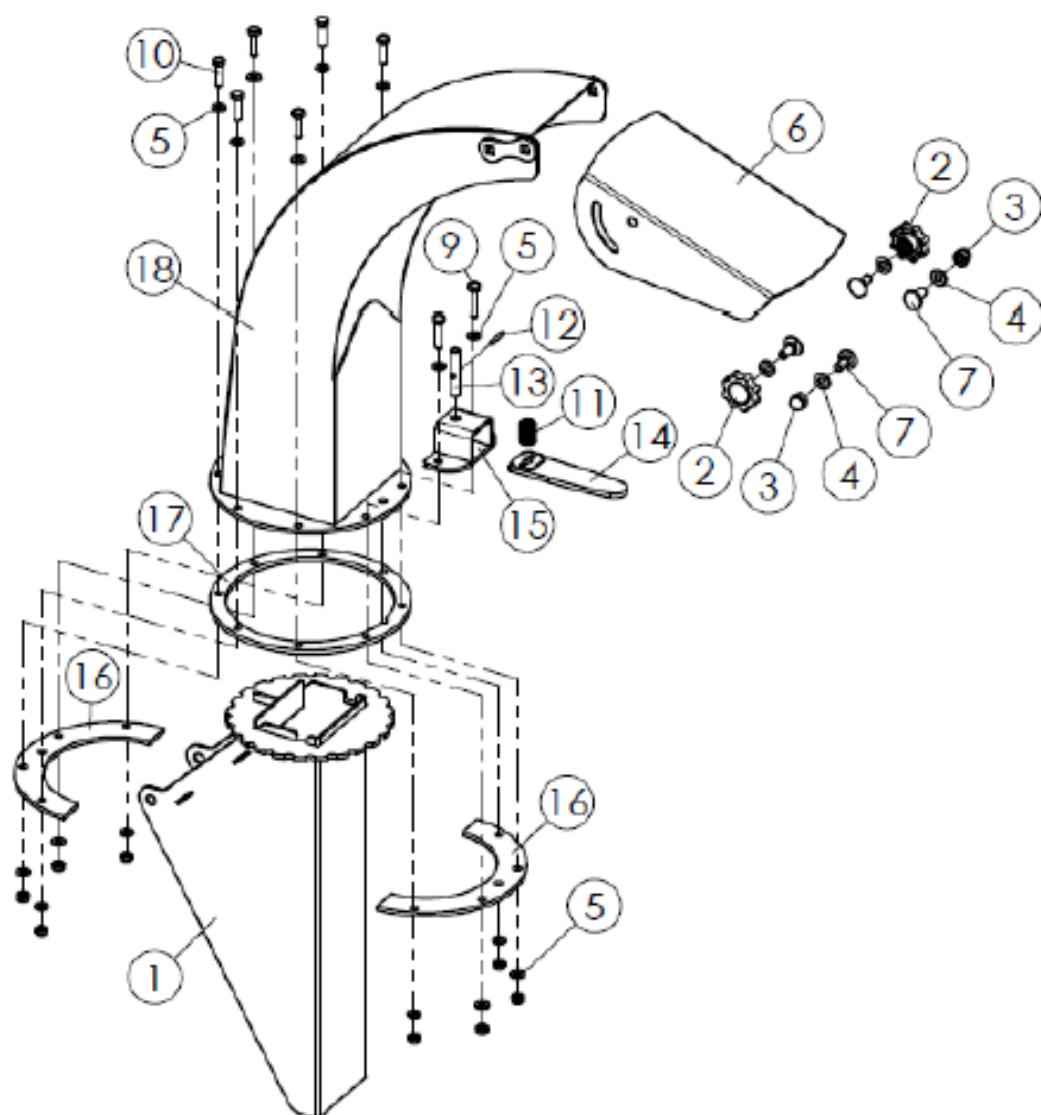

Ser No.	Part No.	Name & Specifications	Quantity
1	WCM8-00015A	排料斗 DISCHARGE PIPE	1
2	WCM8-00042	压紧螺母合件 COMPACT NUT	2
3	GB923-88	螺母 M10 NUT	2
4	GB97.1-85	平垫 10 PLAIN WASHER	4
5	GB97.1-85	平垫 8PLAIN WASHER	16
6	WCM8-10103	导排罩 DISCHARGE COVER	1
7	GB12-88	螺栓 M10×25 BOLT	4
8	DIN985-87	螺母 M 8 NUT	8
9	GB5783-86	螺栓 M 8×35 BOLT	2
10	GB5783-86	螺栓 M 8×30 BOLT	6
11	AM60.01.110	回位弹簧 RECOVER SPRING	1
12	GB119-86	销 B4×28 PIN	1
13	WCM8-10104	锁销 LOCK PIN	1
14	WCM8-00038A	锁销手柄 LOCK PIN HANDLE	1
15	WCM8-00041	锁销架 LOCK PON BRACKET	1
16	WCM8-10101	压板 PRESS BORAD	2
17	WCM8-10102	隔圈 SPACER CIRCLE	1
18	WCM8-00036A	排料管焊合件 DISCHARGE PIPE WELDMENT	1

5.3 减速机构

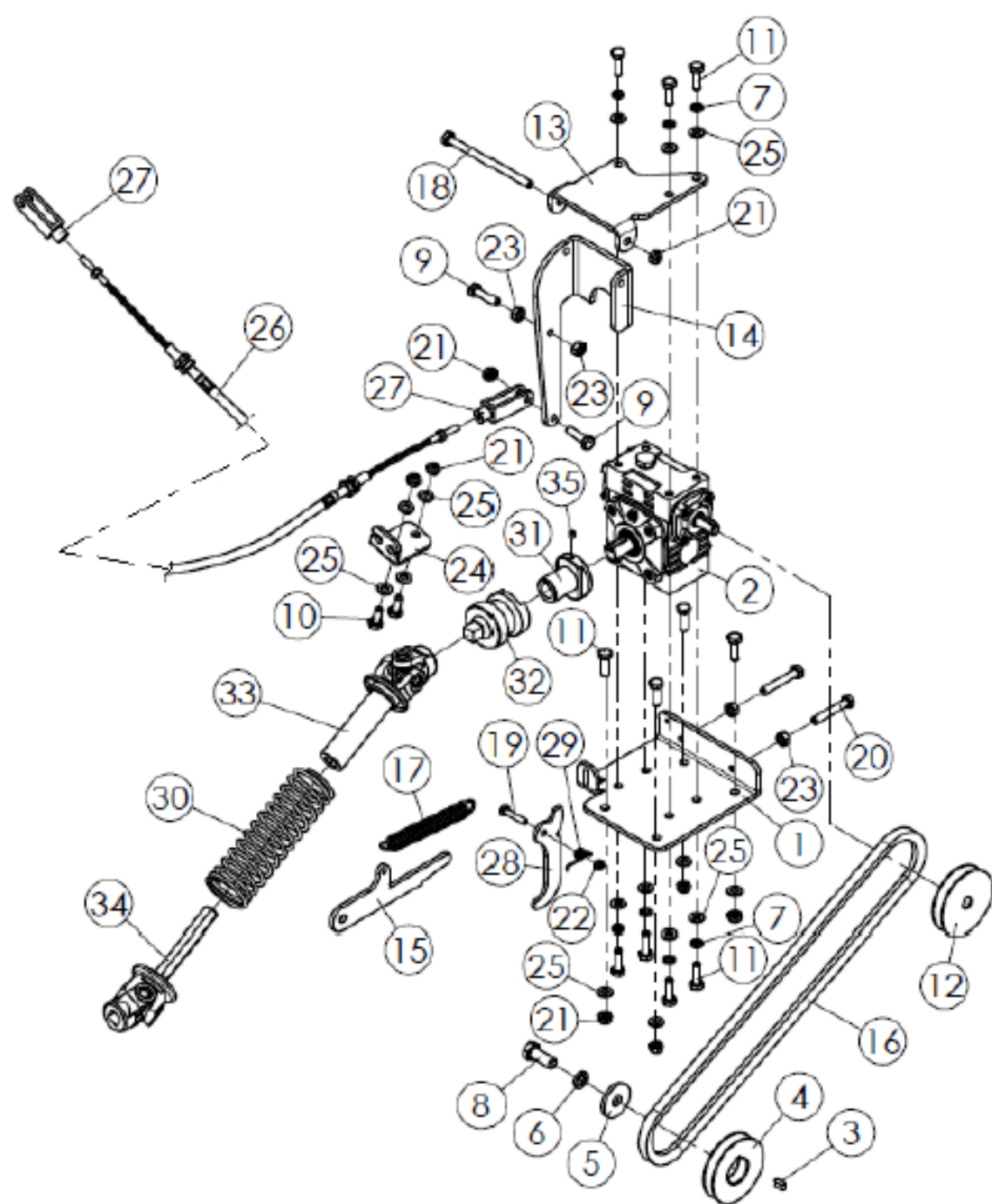

Ser No.	Part No.	Name & Specifications	Quantity
1	WCM8-00187	蜗轮箱底板 REDUCE SUPPORT	1
2	QIAKY01-91	蜗杆减速器 WORM REDUCER	1
3	GB1096-2003	平键 6×14 PLAIN KEY	1
4	WCL8-00130	飞轮轴皮带轮 PULLEY	1
5	MZ105.115	防松垫片 LOCK WASHER	1
6	GB93-87	弹垫 12SPING WASHER	1
7	GB93-87	弹垫 8 SPRING WAHSER	7
8	GB5783-86	螺栓 M12×30 BOLTS	1
9	GB5783-86	螺栓 M 8×30 BOLTS	2
10	GB5783-86	螺栓 M 8×20 BOLTS	2
11	GB5783-86	螺栓 M 8×25 BOLTS	11
12	24PMF.03.105	减速器皮带轮 PULLEY	1
13	WCM8-00183	拨叉座板 SUPPORT BOARD	1
14	WCM8-00182	拨叉板 PULL BOARD	1
15	WCM8-00122	锁板 LOCKING BOARD	1
16	GB11544-97	皮带 A991BELTS	1
17	WCM8-00121	回位拉簧 SPRING	1
18	GB5782-86	螺栓 M 8×120 BOLT	1
19	GB5782-86	螺栓 M 6×30 BOLT	1
20	GB5782-86	螺栓 M 8×50 BOLT	2
21	DIN985-87	螺母 M 8 NUT	8
22	DIN985-87	螺母 M 6 NUT	1
23	GB6170-86	螺母 M 8 NUT	4
24	WCM8-00181	内拉索座 LOCKING SEAT	1
25	GB97.1-85	平垫 8PLAIN WASHER	15
26	WCM8-00022	拉索 LOCKING LINE	1
27	24PMF.03.112	连接叉 CONNECT	2
28	WCM8-00189	解锁板 UNLOCK BOARD	1
29	WCM8-00190	扭簧 SPRING	1
30	24PMF.03.109-1	传动轴 护簧 SPRING	1
31	24PMF.03.107	离合器内牙嵌 INNER CLUTCH CLAW	1
32	24PMF.03.108	离合器外牙嵌 OUTER CLUTCH CLAW	1
33	24PMF.03.017	外传动轴焊合件 OUTER SHAFT	1
34	24PMF.03.018	内传动轴焊合件 INNER SHAFT	1
35	GB78-2000	螺钉 M 5× 8BOLT	1

5.6 刀盘部分

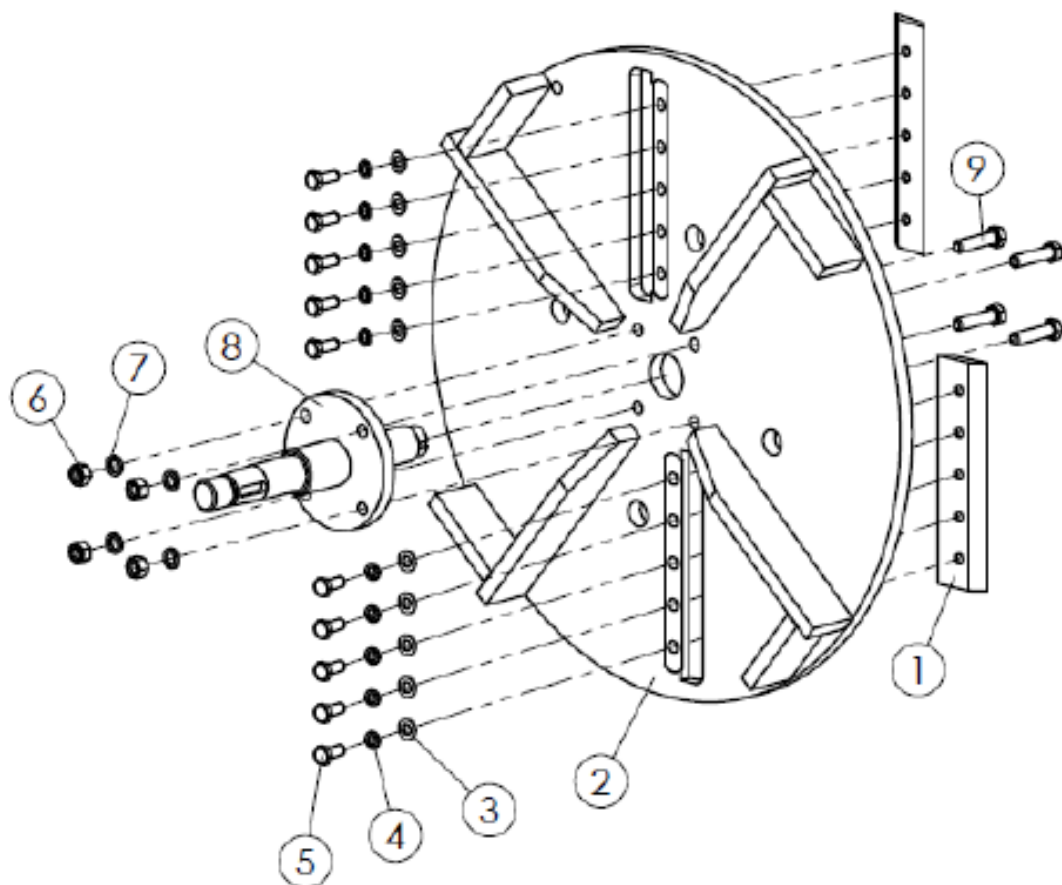

Ser No.	Part No.	Name & Specifications	Quantity
1	WCM8-01101A	动刀 CHIPPER BLADE	2
2	WCM8-01010A	飞轮焊合件 FLY WHEEL	1
3	GB97.1-85	平垫 10 PLAIN WASHSE	10
4	GB93-87	弹垫 10 PAIN WAHSE	10
5	GB5783-86	螺栓 M10×25 BOLT	10
6	GB6170-86	螺母 M12 NUT	4
7	GB93-87	弹垫 12 PLAIN WASHER	4
8	WCL8-01011A	飞轮轴焊合件 FLY WHEEL SHAFT	1
9	GB5782-86	螺栓 M12×50 BOLT	4

5.7 进料部分

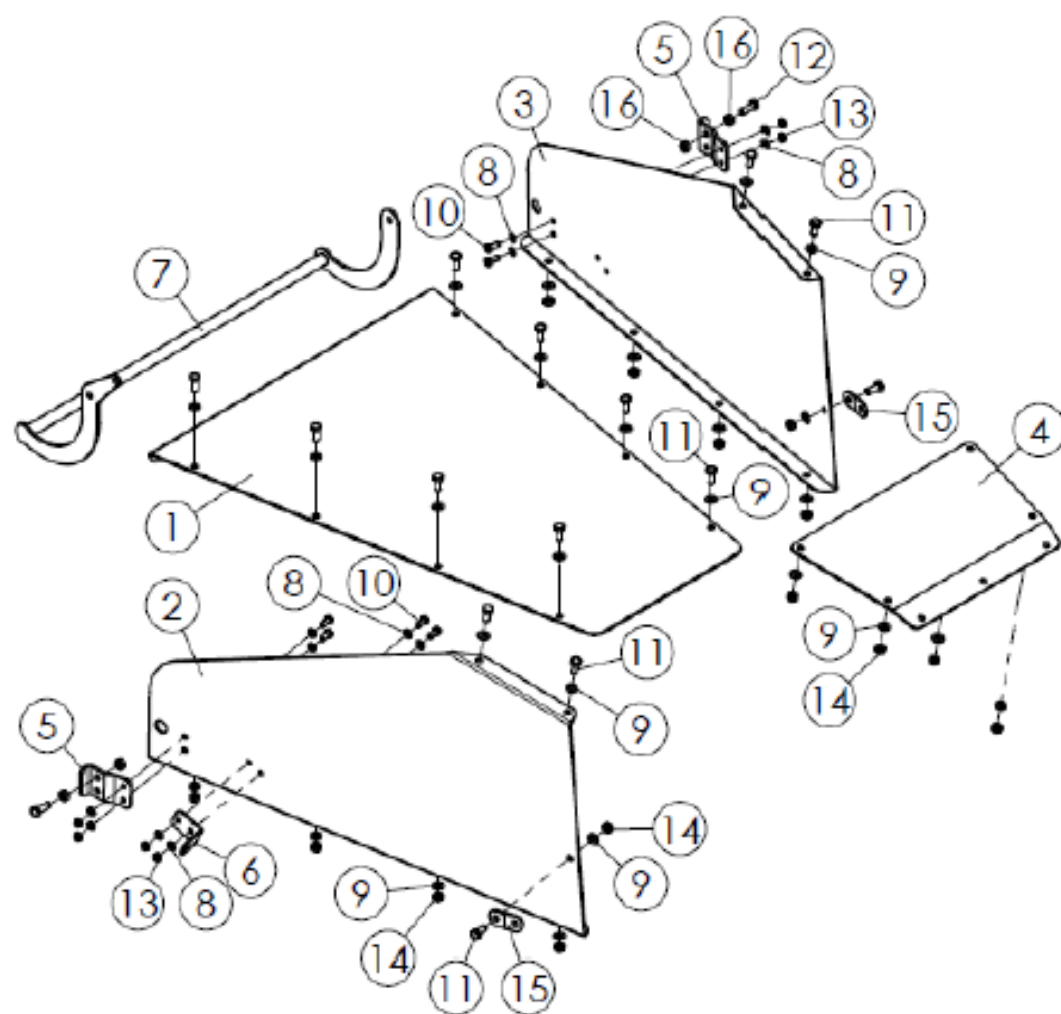

Ser No.	Part No.	Name & Specifications	Quantity
1	WCM8-00118	送料斗底板 BOTTOM PLATE	1
2	WCM8-00117	送料斗右侧板 RIGHT PLATE	1
3	WCM8-00118	送料斗左侧板 LEFT PLATE	1
4	WCM8-00119	送料斗上板 UPPER PLATE	1
5	WCM8-00193	分离操纵杆铰座 CONNECT PLATE	2
6	WCM8-00194	外拉索座 SUPPOT FOR LOCK LINE	1
7	WCM8-00023	离合操纵杆焊合件 LOCK HANDLE	1
8	GB97.1-85	平垫 8 PLAIN WASHER	12
9	GB97.1-85	平垫 10 PLAIN WAHSE	28
10	GB5783-86	螺栓 M 8×20 BOLT	6
11	GB5783-86	螺栓 M10×25 BOLT	14
12	GB5783-86	螺栓 M10×30 BOLT	2
13	DIN985-87	螺母 M 8BOLT	6
14	DIN985-87	螺母 M10 NUT	14
15	WCL8-00120	斗体固定板 FIXED PLATE	2
16	GB6170-86	螺母 M10 NUT	4

5.8 皮带轮罩部分

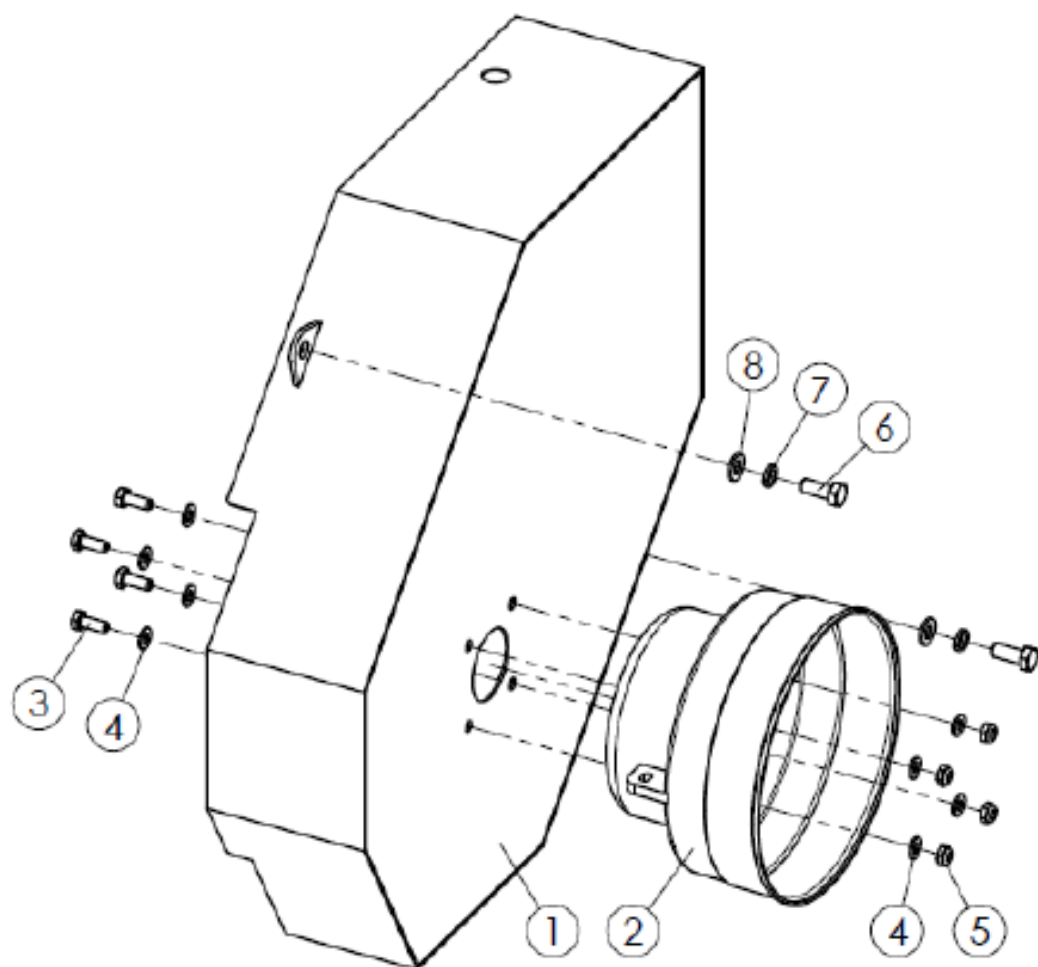

Ser No.	Part No.	Name & Specifications	Quantity
1	WCM8-03011	皮带轮罩 PULLERY COVER	1
2	FM120.00.401	传动轴防护罩 PTO GUARDER	1
3	GB5783-86	螺栓 M 8×20 BOLT	4
4	GB97.1-85	平垫 8 PLAIN WASHER	8
5	DIN985-87	螺母 M 8 NUT	4
6	GB5783-86	螺栓 M10×25 BOLET	2
7	GB93-87	弹垫 10 SPAING WASHER	2
8	GB97.1-85	平垫 10 PLAIN WASHER	2

5.9 涨紧轮部分

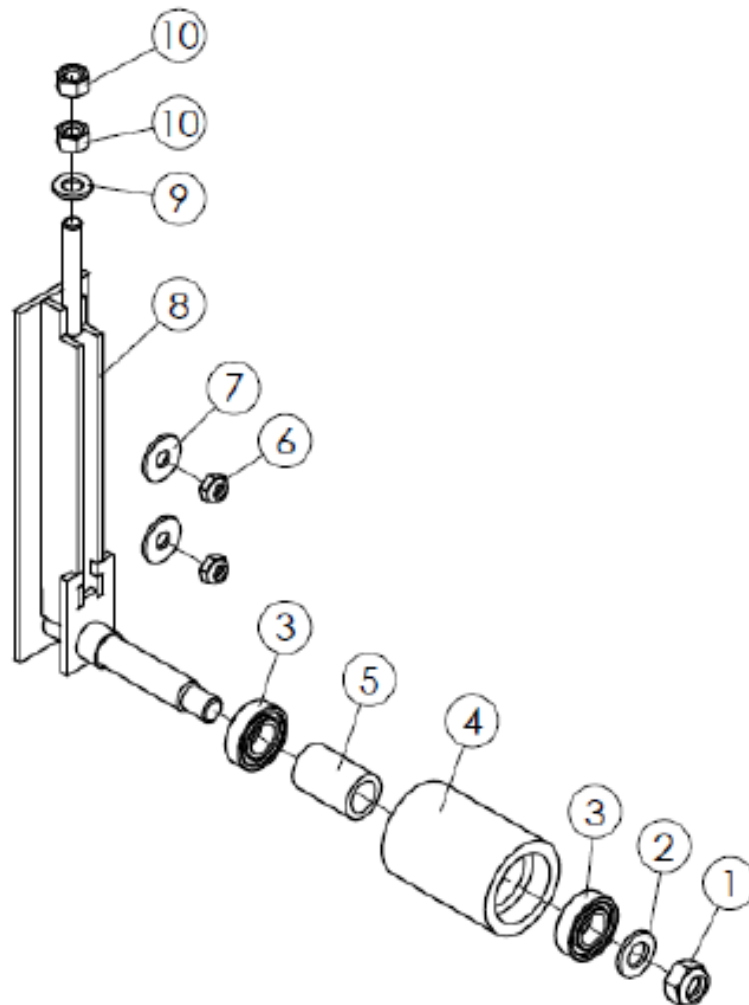

Ser No.	Part No.	Name & Specifications	Quantity
1	GB6184-2000	螺母 M16 NUT	1
2	GB97.1-85	平垫 16 PLAN WAKER	1
3	GB276-1994	轴承 104 BEARING	2
4	WCL8-00106	张紧轮 TIGHT WHEEL	1
5	WCL5-00107	隔套 SPACER	1
6	DIN985-87	螺母 M10 NUT	2
7	GB96.2-2002	平垫 10 WASHER	2
8	WCL5-00016	张紧轮架 TIGHT WHEEL SUPPORT	1
9	GB97.1-85	平垫 12 PLAIN WASHER	1
10	GB6170-86	螺母 M12 NUT	2